

Easybar®

CRAFTED DRAFT

BEER AND WINE DISPENSING SYSTEMS

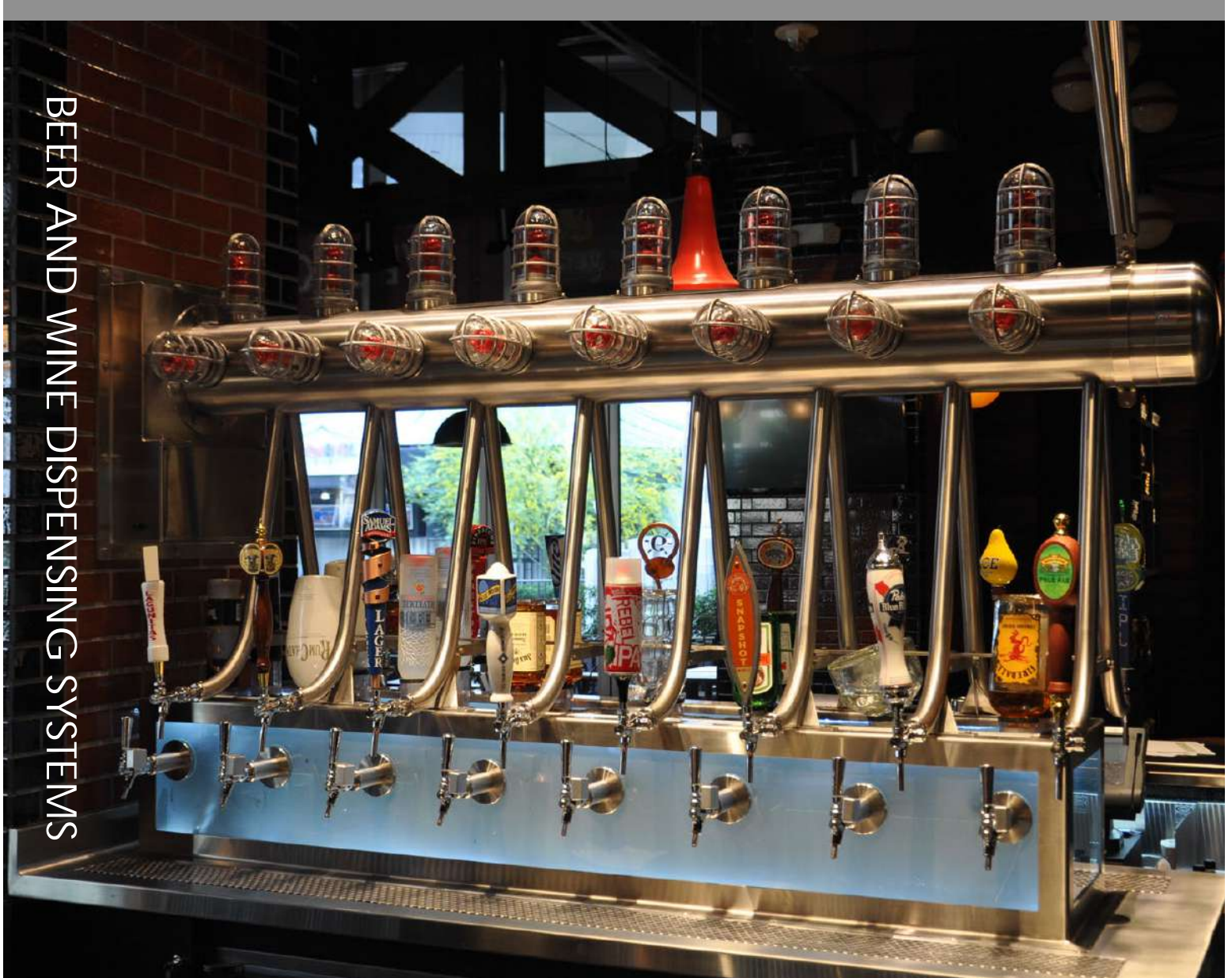

EASYBAR DRAFT DISPENSING SYSTEMS

EASYBAR WAS ESTABLISHED IN 1968 AND SINCE THAT TIME HAS BEEN A LEADING MANUFACTURER AND INSTALLER OF BEVERAGE DISPENSING SYSTEMS WORLDWIDE.

EASYBAR DRAFT BEER AND WINE DELIVERY SYSTEMS ENSURE THAT CLIENTS RECEIVE THE HIGHEST RETURN ON THEIR INVESTMENT AND ARE BACKED BY EASYBAR'S BEST IN CLASS SERVICE NETWORK.

WITH OVER FORTY YEARS OF EXPERIENCE IN THE BEVERAGE INDUSTRY, EASYBAR HAS THE SOLUTION FOR ALL OF YOUR DRAFT DISPENSING NEEDS.

EXPERIENCE INNOVATION WITH EVERY POUR.

BEND, OR – PORTLAND, OR – LAS VEGAS, NV

Ph: 503.624.6744 | Fax: 503.624.6741

Email: info@easybar.com

WWW.EASYBAR.COM



LOVE DRAFT BEER.





"I want everyone to know how pleased we are with the system Easybar recommended and has installed. The beer is pouring better than it ever has. This will relate to a good cost savings and we can now promote a quality product for our partners! Thank you."

Janet Rector, Harrah's Las Vegas



"As our corporate supplier for beverage dispensing systems, Easybar has improved the quality of our draft beer and liquor equipment, increased ease of service, and built a trustworthy relationship with our corporate management. We are excited to continue working with Easybar and would recommend their services to any business looking to improve and expand their beverage program."

Chris Picone
Director of Strategic Sourcing, National Beverage
Caesars Entertainment



"Easybar liquor control and draft beer systems were our top choice for South Point Casino. Over the years these systems have been extremely reliable and functional. Easybar provides excellent customer service coupled with the finest quality beverage dispensing equipment in the industry."

Steve Delmont
Vice President of Food and Beverage
South Point Hotel Casino and Spa



BUILDING A FIRST RATE DRAFT SYSTEM

Easybar ensures that the planning and installation process for your draft beer system is enjoyable and efficient. Our skilled technicians offer advice and provide various options for every customer's needs. At Easybar we realize that each client's needs are different and that is why we customize every system to fit the individual property.

The information in this catalog will offer insight into the individual parts of draft beer delivery systems and provide information on each of the following components sold by Easybar Beverage Dispensing Systems:



EASYBAR COOLER SETUP

EASYBAR GLYCOL CHILLERS

EASYBAR BEER TOWERS

EASYBAR BEER TRACKING



EASYBAR

BEER COOLER SETUP

Remote draft beer systems require regulated gas pressure to transport beer from the keg cooler to the bar area. If a system is pumping over 100' then beer pumps are recommended to assist in the dispensing process. Pumps help maintain the recommended pressure allowing the beer to travel greater distances. Easybar cooler kit systems include foam protection devices (FOBS) and two single-gauge regulators to ensure proper pressure application. With Easybar cooler kits you can rest assured that your beer will be delivered to the glass with the perfect pressure, every time.

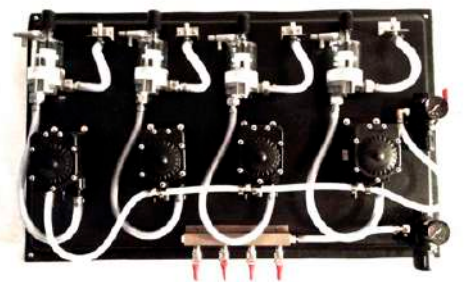

COOLER KIT COMPONENTS



BEER TUBING

Easybar bundled beer product lines are sealed in an extruded jacket with moisture wrap and are further insulated with 1/2" foam. These measures ensure that all beer lines stay glycol chilled on the way to the beer faucet for dispensing.



BEER PUMP

Beer pumps are designed for dispensing draft beer from a keg cooler. Gas pressure is applied to the pump and the beer individually, optimizing the pressure for the system and maximizing the distance capability while keeping the recommended pressure stable.



BEER REGULATOR

Beer regulators control the pressure from the gas cylinder to the keg coupler. The pressure regulator contains a manual-adjusting knob to regulate the amount of pressure supplied to the keg. A properly functioning regulator is critical in maintaining the proper level of CO₂ in the beer as too much CO₂ pressure may cause foaming problems and too little CO₂ pressure may cause flat-tasting beer.



FOAM ON BEER DETECTOR

FOB detectors sense an empty keg or other foaming issues and shut down the flow of beer in the line. FOBs allow the beer lines to remain full when the keg empties. Since there is no need to re-fill the beer line when attaching a new keg, waste is reduced and the number of glasses served per keg is maximized.

EASYBAR

CRAFTED DRAFT GLYCOL CHILLING SYSTEMS

Easybar glycol chillers ensure that your beer is delivered perfectly chilled to the point of dispense. Our units are offered in both air-cooled and water-cooled models

Easybar chillers are available in ½ HP, ¾ HP, 1 HP, and 1 ½ HP

Chillers can be equipped with either single or dual pumps

All chillers include a digital temperature gauge and digital temperature adjustment

Unit is built to commercial standards

Made in the USA



Perfectly chilled beer starts and ends with a state-of-the-art glycol chiller. We have combined our knowledge in over 40 years in the beverage dispensing industry with the expertise of one of the most respected refrigeration companies in the world to develop four models of commercial-grade glycol chillers. Easybar glycol chillers are built to handle the longest line runs and most demanding conditions, to ensure that your beer is served at your perfect temperature, every time.

SAMPLE SPECIFICATIONS SHEET

GENERAL DESCRIPTION- Glycol Chiller is designed to maintain the temperature of draft beer from the keg storage cooler to the dispensing station. This is accomplished by refrigerating food grade propylene glycol in a reservoir and recirculating it through polyethylene lines, attached to separate beer lines from the cooler to the dispensing station. Each machine consists of a 5-gallon sealed tank, glycol holding reservoir, circulating pump and motor, easy to read digital return temperature gauges, and individual ON/OFF illuminated rocker switches controlling circulating pump and motor.

1 HP AIR COOLED GLYCOL CHILLERS

Required Fuse Size-Dedicated	20amp, 208v/1ph.
Reservoir Capacity-Gallons	5 Gallons
Circulating Pumps	1-2 pumps, 100 GPH
Dimensions	35 ¼ x 25 ¼ x 16 ¼
Weight	250 lbs.
Safety Listings	ETL listed
Maximum Distance	500'
Water Cooled	NO
Drain Required	NO
BTU	8.6
Voltage	208/1ph.
Overall Run Amps (RLA) Compressor	9.2 amps
Refrigerant	R-404a
Compressor Horse Power	1 H.P.
Cabinet	Galvanized. Painted, Stainless Steel

EASY BAR

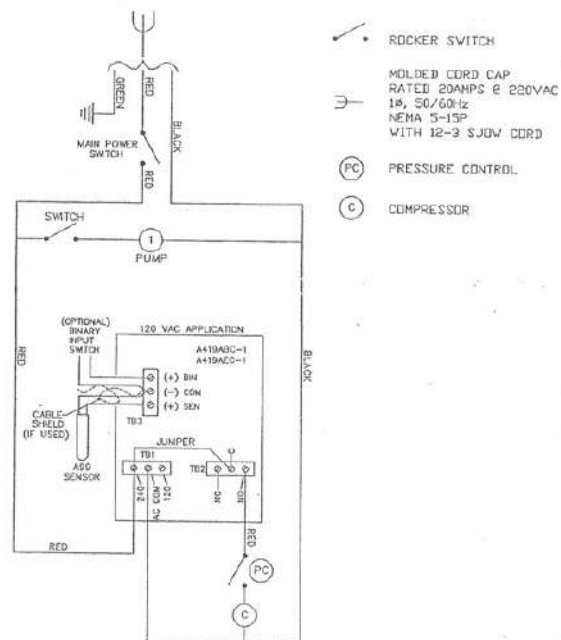
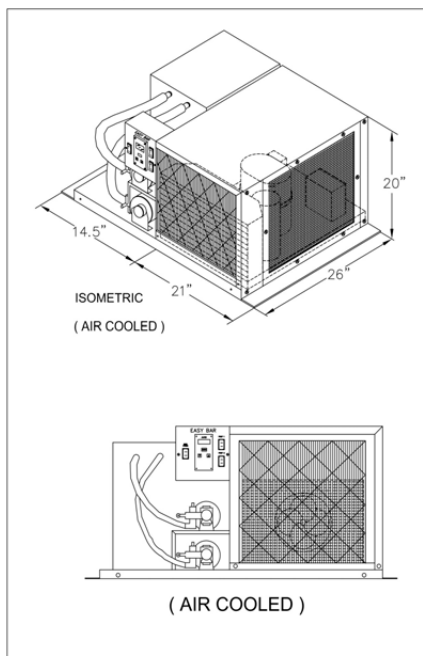

Hookups and Connections

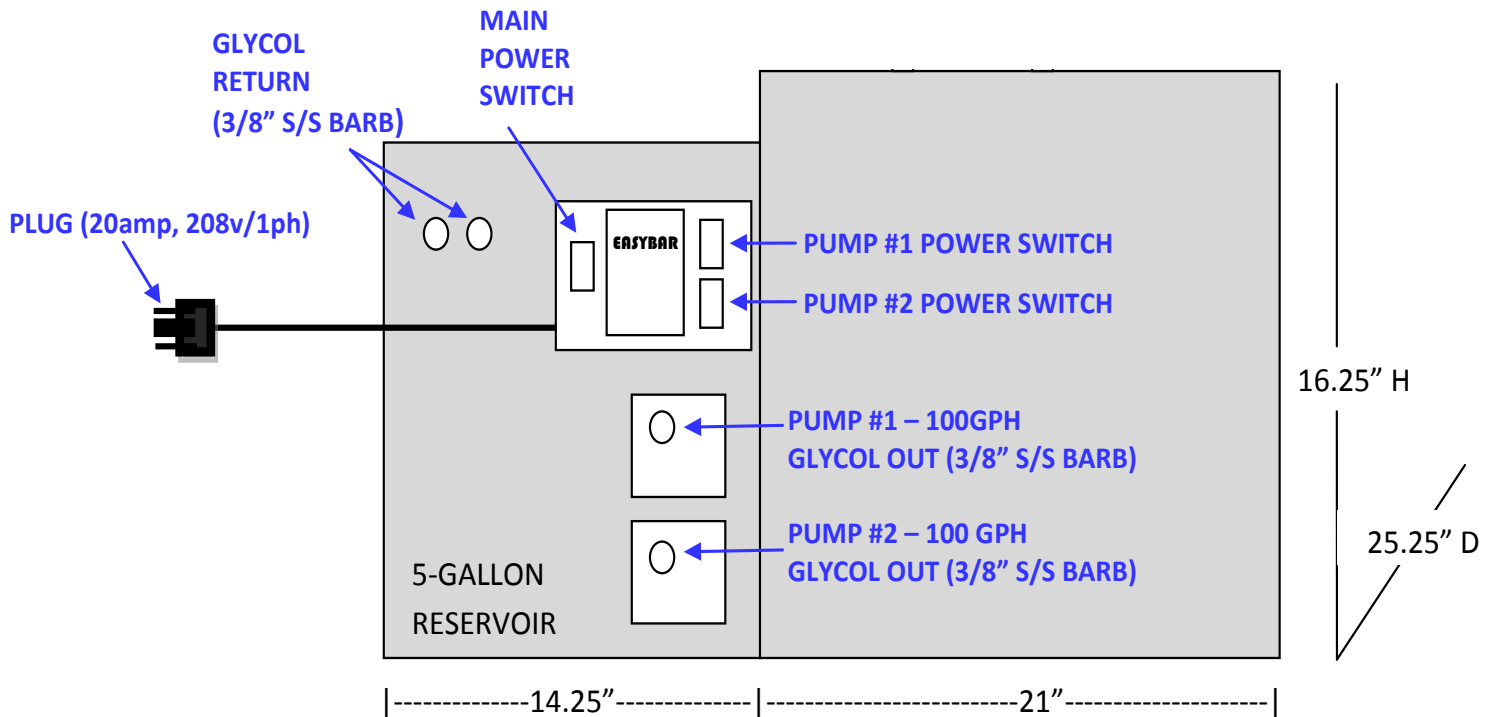



DRAFT DISPENSING TOWERS

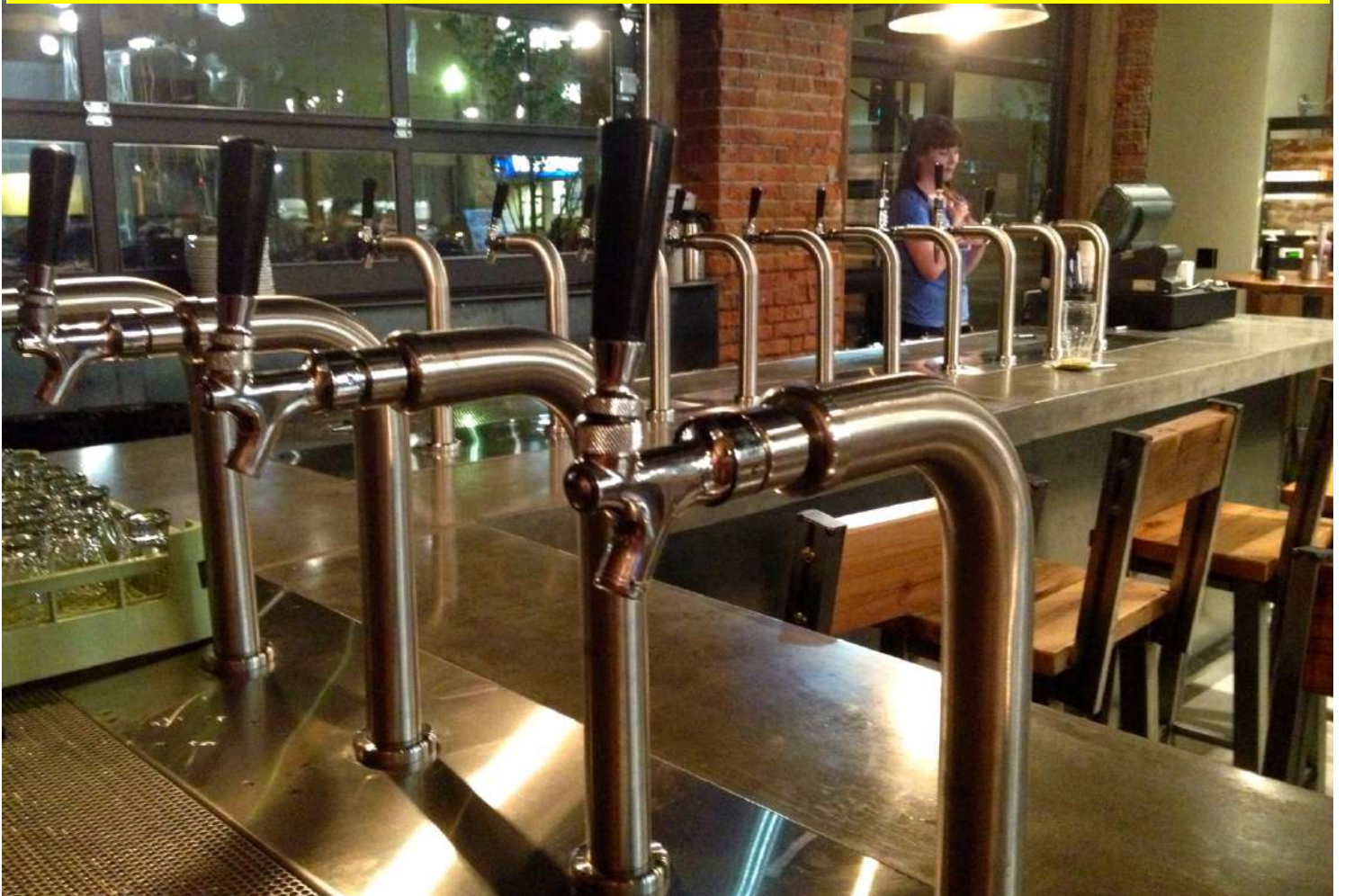

EASYBAR BEER TOWERS



EASYBAR DOMESTIC TOWER

- Brushed stainless steel
- Glycol or air-chilled models available
- 2 - 8 faucet configurations



EASYBAR BEND TOWER

- Brushed stainless steel
- Glycol chilled
- Single faucet configuration



EASYBAR BRIDGE TOWER

- Brushed stainless steel
- Glycol or air-chilled models available
- 8 - 20 faucet configurations

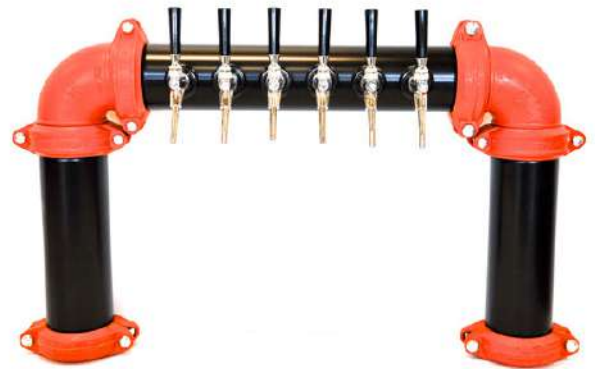

EASYBAR FIRE TOWER

- Matte black with orange fittings
- 304 Stainless Steel
- Glycol or air-chilled models available
- 6 - 20 faucet configurations



WALL MOUNT TOWER

- Polished stainless steel
- Glycol or air-chilled models available
- 2, 3, 4, 5, 6, 8, and 10 faucet configurations



GOTHIC TOWER

- Polished stainless steel
- Glycol chilled
- 2, 3, and 4 faucet configurations



BRAUHAUS TOWER

- Polished stainless steel
- Glycol chilled
- 8 faucet configuration



SILVA TOWER

- Ceramic
- Glycol or air-chilled models available
- 1 - 6 faucet configurations



MILANO TOWER

- Polished stainless steel
- Glycol chilled
- 1 - 4 faucet configurations



HAVANA TOWER

- Polished stainless steel
- Glycol chilled
- 3 - 6 faucet configuration



BREW PIPE TOWER

- Stainless steel
- Glycol chilled
- 10 - 20 faucet configurations



COBRA TOWER

- Chrome finish
- Glycol chilled and ICE models available
- Illuminated product medallions available
- 1, 2, 3, and 4 faucet configurations

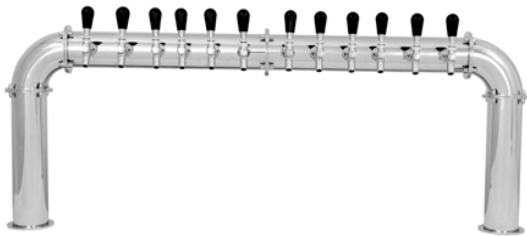

ARCADIA TOWER

- Polished stainless steel
- Glycol chilled
- 6, 8, 10, and 12 faucet configurations



COLUMN TOWER

- Polished stainless steel
- Glycol or air-chilled models available
- 1 - 4 faucet configurations



TERRA TOWER

- Polished stainless steel or brass
- Glycol chilled
- 6, 7, and 8 faucet configurations



BEER ENGINE

- For dispensing cask kegs
- ¼ pint single pull hand pump
- 1 faucet configurations

The Easybar FIRE Tower



Give a truly unique look to your bar with the 2016 Easybar Fire Tower. These towers are made with 304 Stainless steel to provide strength and durability while providing a rustic urban feel. Tired of standard stainless steel beer towers? Easybar has the answer.

- Matte black with orange pipe fittings
- 4" 304 Stainless steel pipe
- Glycol or air-chilled models available
- 6 - 20 faucet configurations



CUSTOM TOWER SETUPS

Contact Easybar to discuss custom fabrication and setup for tap systems. Easybar manufactures and installs a variety of custom draft setups for some of the largest names in the restaurant and entertainment industries.



OTHER EASYBAR SYSTEM PARTS



GAS BLENDERS

- Requires no electricity, on-going maintenance or adjustment
- Can be used equally well with all sources of clean nitrogen and CO2 including high pressure cylinders, bulk tanks or separators
- Up to 15 kegs per hour



KEG COUPLERS

- American sankey coupler is the most common beer coupler available in the US and Canada. Most major breweries and craft breweries use it.
- We also offer European couplers. Please contact us for model types.



BEER SHANK ASSEMBLYS

- Available in a variety of lengths and bore sizes
- Stainless Steel



BEER FAUCETS

- Body made of chrome plated forged brass
- Faucet lever made of brass
- Quick handle action
- Fits North American shanks or towers
- Stout faucet is chrome plated
- Euro faucet, with flow controls

DRIP TRAYS (Other varieties available)

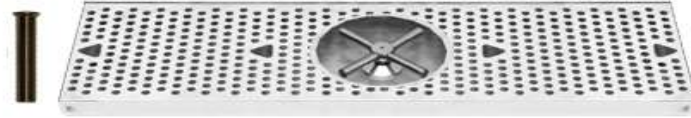

COUNTER TOP DRIP/RINSER

- Stainless steel, welded corners, brushed finish
- Various sizes
- Two plastic drains are included
- Durable metal single spray rinser



COUNTER TOP DRIP

- Stainless steel, welded corners, brushed finish
- Various sizes
- Two plastic drains are included



GLASS RINSER

- Stainless steel
- Counter top, with a drain

THE ART OF DRAFT BEER DISPENSING

Easybar Beverage Dispensing Systems

There is true beauty in a perfectly poured pint. A moment of transcendence as the brewer's soulful essence slips from the tap to the glass, breathing in the surrounding world. Water, yeast, malt and hops, born anew. The golden glow of fine ale, like rust colored waves of grain, brings tears to a grown man's eyes and warmth to his heart. What could be better than a perfectly poured pint? Yet how often do we think about the journey of this sweet elixir? When did you last consider the path of your beer from the keg to the glass?

This journey is filled with pitfalls and danger, complications and calculated risk. To ensure a safe passage, the beer must have a guide. Someone to ensure the brewer's creation will reach the drinker exactly the way it was intended to smell, look and taste, guaranteeing highest quality and enhanced experience.

Easybar draft beer dispensing systems ensure that each beer is served with its intended quality, clarity, temperature, taste and carbonation intact. No beer deserves to be improperly delivered and we at Easybar pride ourselves on providing a system that is simply an extension of the keg or bright tank, dispensing your beer with care, one pint at a time.

Contact Easybar Beverage Dispensing Systems to experience the difference and ensure your quality of product remains unchanged. Easybar Beer Dispensing Systems, now serving the perfect pour.



EASYBAR GROWLER FILLING SYSTEMS



Create your own custom growler filling station with Easybar draft beer systems!

- Increase revenue!
- Reinvent business image!
- Attract new clients and ensure return customers!
- Minimum investment for maximum returns!

A conservative sample of return on investment...

- 20 Growlers/day
- 140 Growlers/week
- \$12.00 average fill cost (beer only)
- \$1,680.00/week
- Yearly \$80,640.00 revenue

In 7 weeks a standard Easybar system is paid off. Why invest in an EASYBAR growler filling station??? **BECAUSE IT MAKES YOU MONEY.**

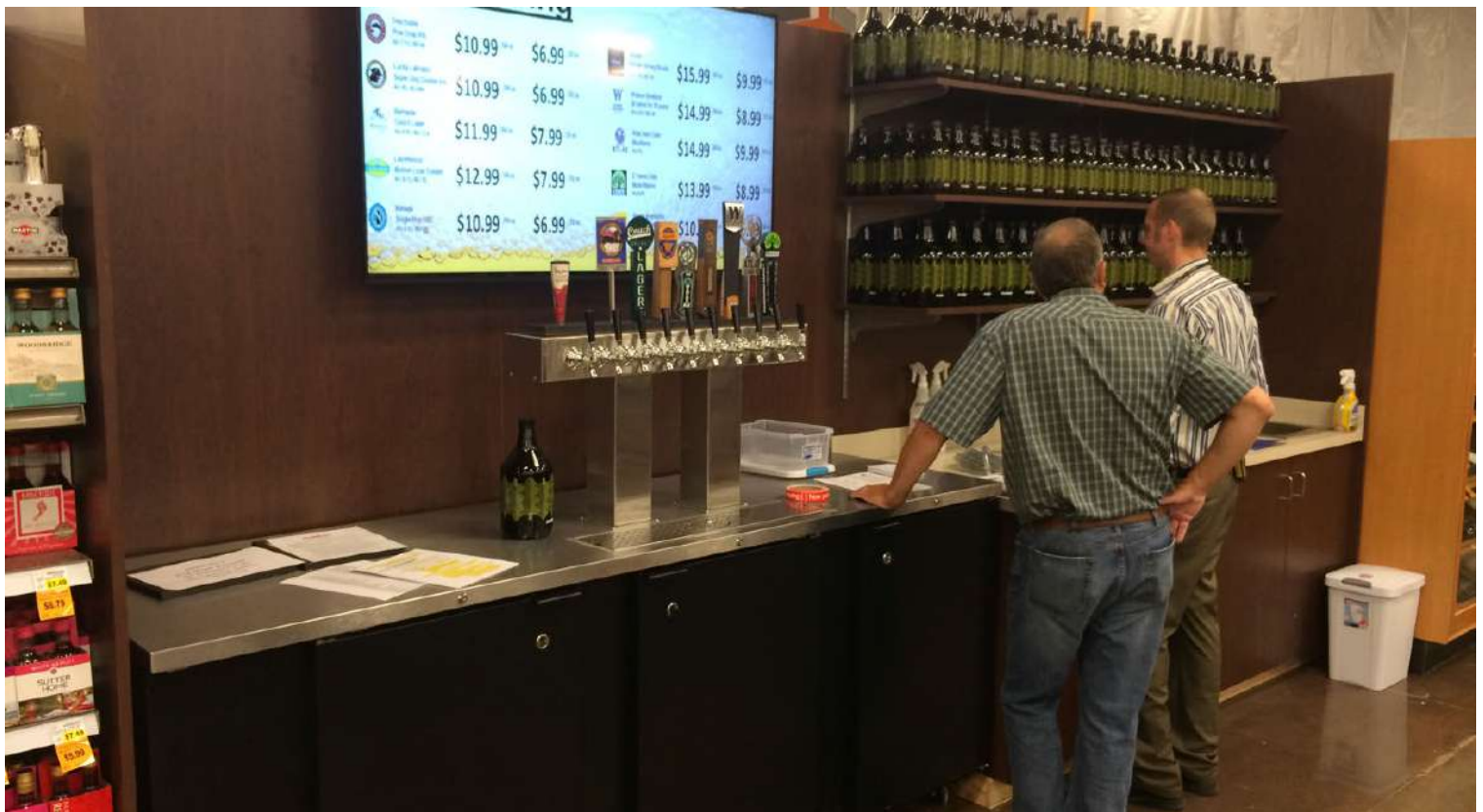

DRAFT WINE DISPENSING EQUIPMENT

Straight from the vineyard tanks to your glass.
Unfiltered and unchanged.
Purity and perfection in every pour.

- Environmentally friendly
- Wine is preserved in a more stable atmosphere
- No wasted bottle or cork material
- No more throwing out unused or old portions of wine as wine preserved until the keg is empty
- Eliminates breakage or spillage from using bottles
- A variety of wine towers are available to showcase brands and increase interest



CONTACT US TODAY ABOUT OUR STATE OF THE ART DRAFT WINE SYSTEMS!



FROST WALL SYSTEMS

Keep the chill in your beer.

Easybar frost walls give a unique and beautiful look to any venue while increasing sales of draft beer and wine.



Easybar and Fire and Ice Designs present frost wall systems.

Powered by Easybar's commercial chilling systems and serving up the perfect pour with Easybar's draft dispensing equipment from keg to glass, these frost wall systems promote your draft offerings in a way that has never before been accomplished. Capitalize on the craft beer boom with Frost Wall Systems!

PORTION CONTROLS FOR DRAFT SYSTEMS



- Beer controls can be installed with a custom draft system or be added to an existing system
- Easybar electronics can control any number of brands
- Each brand is assigned 3 pour sizes
- Multiple beers or wine can be poured at the same time
- Each pour is counted and dispensing information can be organized in valuable usage reports
- When used with Easybar CLCSII electronics, beer controls can ring up drinks on compatible POS systems
- Draft controls can be used in conjunction with all Easybar liquor control systems and offer complete control and accountability for all draft systems

EASYDRAFT BEER METERING SYSTEM

Easybar is now offering the Easydraft radio frequency flow metering system! This system reports every ounce poured from your taps to Easydraft metering software as well as to your POS reporting system. With every pull of the tap handle Easydraft will count the ounces being dispensed so that you can see exactly where your beer investment is going.



Pour Report for EasyBar Wireless Tap Reader
Data Read: 8/15/2012 4:17:24 PM

Units Reporting: BEER TAPS-0C080E0210191A000003
First Pour: 8/15/2012 4:16:00 PM
Last Pour: 8/15/2012 4:17:00 PM

BEERS POURED

#	Brand	PS1	PS2	PS3	PS4	Cost	Retail	Profit
3	BLACK BUTTE PORTER	1	0	0	0	(\$1.01)	\$4.00	\$2.99
1	WIDMER-HEFFE	2	0	0	0	(\$2.13)	\$8.00	\$5.87
	TOTALS	3	0	0	0	(\$3.14)	\$12.00	\$8.86

BEER INVENTORY REPORT

#	Brand	Volume Poured [oz]	Kegs Used [15.5gal]	Over Pour Waste [oz]	Waste Loss
3	BLACK BUTTE PORTER	13.6	0.01	-2.4	\$0.18
1	WIDMER-HEFFE	30.2	0.02	-1.8	\$0.13
	TOTALS	43.8	0.02	-4.2	\$0.31

BOTTOM LINE

Cost	Retail	Profit
(\$2.83)	\$12.00	\$9.17





A FEW OF OUR DRAFT CLIENTS

Caesars Entertainment – Multiple Locations
Gordon Ramsay Restaurants - Multiple Locations
Northern Quest Casino - Airway Heights, WA
Aliante Station - Las Vegas, NV
Buffalo Thunder - Santa Fe, NM
Johnny Rockets - New York, NY
Mirage Casino - Las Vegas, NV
Diamond Jo Casino - Dubuque, IA
Jumers Casino - Rock Island, IL
Wynn Casino - Las Vegas, NV
Encore - Las Vegas, NV
Golden Nugget - Las Vegas, NV
New York, New York - Las Vegas, NV
Treasure Island Casino - Las Vegas, NV
Crux Fermentation - Bend OR
Mt. Bachelor Resort - Bend OR
Ballys Casino - Las Vegas, NV
Bellagio Casino - Las Vegas, NV
Excalibur Casino - Las Vegas, NV
Luxor Casino - Las Vegas, NV
Planet Hollywood Casino - Las Vegas, NV
Hard Rock Casino - Las Vegas, NV
Worthy Brewing - Bend, OR
10 Barrel Brewing - Bend, OR, Boise, ID
Harrahs Casino – Multiple Locations
Venetian/Palazzo Casino - Las Vegas, NV
Big Al's Entertainment Center - Meridian ID
Mt. Hood Resort- Mt. Hood, OR

Maryland Live Casino - Hanover, MD
Hollywood Casinos - Multiple Locations
Aqueduct Casino - Jamaica, NY
Plaza Casino - Las Vegas, NV
Henry's Brew Pub - Portland, OR
Oswego Grill - Wilsonville, OR
Charles Town Races - Charles Town, WV
Rivers Casino - Des Plaines, IL
Paris Casino - Las Vegas, NV
Ringside Steakhouse - Portland, OR
Gun Lake Casino - Wayland, MI
Sugar House Casino - Philadelphia, PA
Orleans Casino - Las Vegas, NV
South Point Casino - Las Vegas, NV
Black Bear Alehouse - Garden City, NY
Mohegan Sun Pocono Downs - PA
Hofbrauhaus - Multiple Locations
Snowshoe Mountain Resort - Snowshoe, WV
Calder Racetrack - Wintergarden, FL
Monte Carlo Casino - Las Vegas, NV
Rivers Casino - Pittsburgh, PA
Four Seasons - Kona, HI
Alderbrook Golf Course - Tillamook, OR
Meadows Casino - Pittsburgh, PA
Rio Casino Resort - Las Vegas NV
Fox and Bear Public House - Tri Cities, WA
Graton Rancheria Casino – Sanoma, CA
Pub 1842 – MGM Las Vegas, NV
Growler filling stations – Nationwide

EASYBAR BEVERAGE DISPENSING SYSTEMS

19799 SW 95th Ave Suite A Tualatin, OR 97062

Ph: 503.624.6744 | Fax: 503.624.6741

Email: info@easybar.com

www.easybar.com

LOVE DRAFT BEER.

www.easybar.com

